



GENUINE PARTS

INSTALLATION INSTRUCTIONS

DESCRIPTION: Weight Distributing Hitch Ball Mount Class IV

APPLICATION: Titan

PART NUMBER: 999T5 W3199

KIT CONTENTS:

Item	Qty.	Part Description	Service Part Number
A	1	Ball Mount	---
B	1	Reducer Bushing	---
C	2	Lock washer 3/4 Plated	---
D	1	Pull Pin	---
E	1	Spring Clip	---
F	2	Nut, Hex 3/4-10 GR5	---
G	2	Adjustable Washer	---
H	1	Bolt, Hex Head 3/4-10 x 5.5	---
I	1	Bolt, Hex Head 3/4-10 x 4.5	---
J	1	Ball Mount Shim	---
K	1	Leverage Handle	---
L	2	Safety Pin	---
M	2	Snap Up Bracket	---
N	2	Spring Bar	---
O	2	Bolt Square Head 1/2-13 x 3.50	---
P	4	Locknut Hex 3/8-16 GR2	---
Q	4	Washer Flat 3/8	---
R	2	Chain (9 Link)	---
S	2	U Bolt	---
T	1	Ball 2-5/16 x 1 1/4 x 2 3/4 (Chrome)	---
U	1	Lock Washer 1 1/4	---
V	1	Nut 1 1/4	---
W	1	Installation Instruction Replacement Template	999V2 AW000

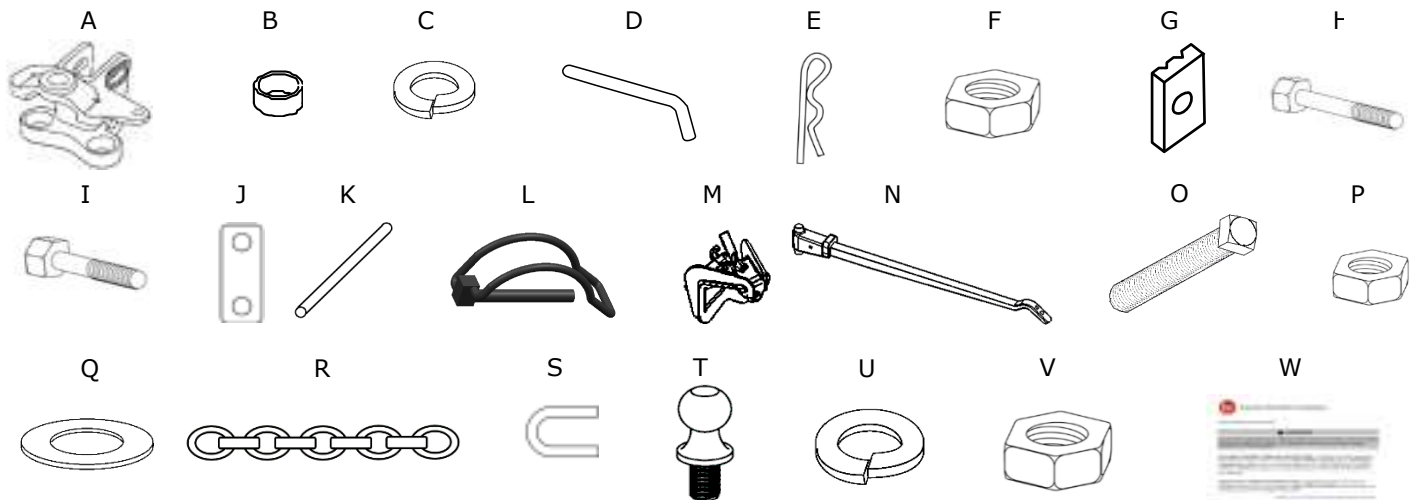

TOOLS REQUIRED:

- 12 mm Wrench or Ratchet & Socket
- 14 mm Wrench or Ratchet & Socket
- 1 3/4" Wrench
- Tape Measure (at least 6 feet)
- Tire Pressure Gage
- 28 mm Wrench or Ratchet & Socket
- 29 mm Wrench or Ratchet & Socket
- 46 mm Wrench
- Torque Wrench (1 5/8" or 40 mm Open Wrench)

PRE-INSTALLATION WARNINGS, CAUTIONS, CRITICAL STEPS, and NOTES: **WARNING**

- **Refer to your owner's manual for important information about installation, towing capacity, and weight distribution. The owner's manual can be downloaded at the following website:**
- <https://owners.nissanusa.com/nowners/navigation/manualsGuide>
- **Tongue rating of trailer hitch must meet or exceed measured tongue weight of trailer.**
- **Total trailer gross weight rating must never exceed tow vehicle rated gross tow rating.**
- **Ensure kit components are properly stowed when not in use. Improperly stowed components could result in serious personal injury during a collision or sudden stop.**
- **DO NOT LUBRICATE ANY THREADS**

INSTALLATION PROCEDURE: PRE-INSTALLATION

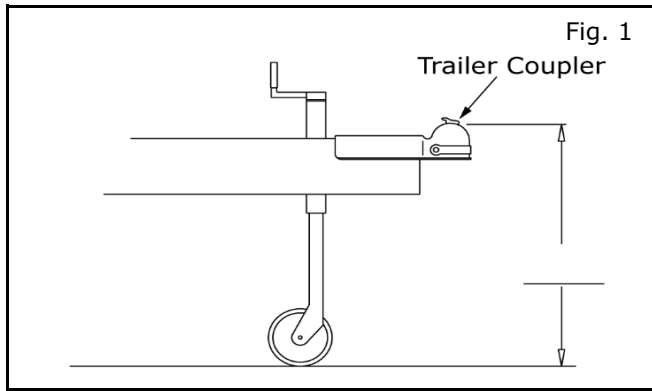

- 1) Line up tow vehicle and trailer on level pavement in straight-ahead position, uncoupled.
- 2) Level trailer then measure and record distance from pavement to top of coupler. See Fig. 1 using a tape measure.

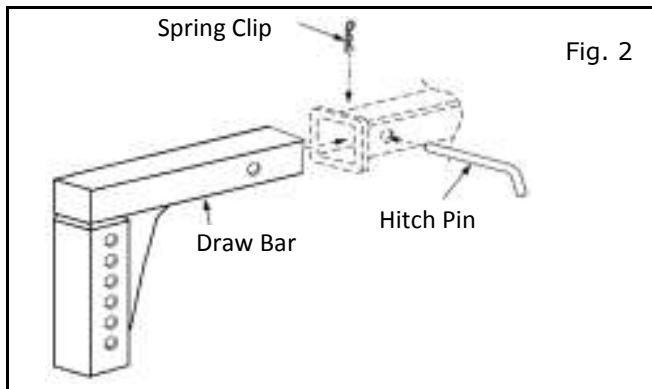

- 3) Installing Draw Bar.
 - a) Insert draw bar into hitch receiver tube. Install hitch pin and spring clip. See Fig. 2.

NOTE:

Draw bar may be used in either up or down position.

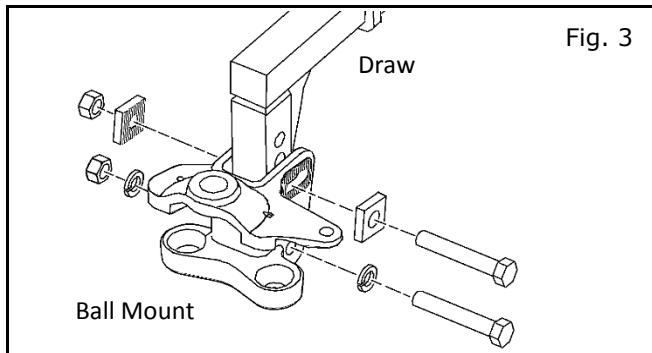

- 4) Installing Ball Mount.
 - a) Loose install one 3/4 x 4 1/2" bolt (I) through lower hole in ball mount and install two 3/4" lock washers (C) and 3/4" nut (F). See Fig. 3.

NOTE (Optional):

Insert ball mount shim (J) if there is excessive space between draw bar and ball mount.

- b) Loose install one 3/4 x 5 1/2" bolt (H) through upper hole in ball mount and install two 3/4" adjustment washers (G) and 3/4" nut (F). See Fig. 3.
 - c) Rotate ball mount to the center of adjustment range and hand tighten all fasteners.

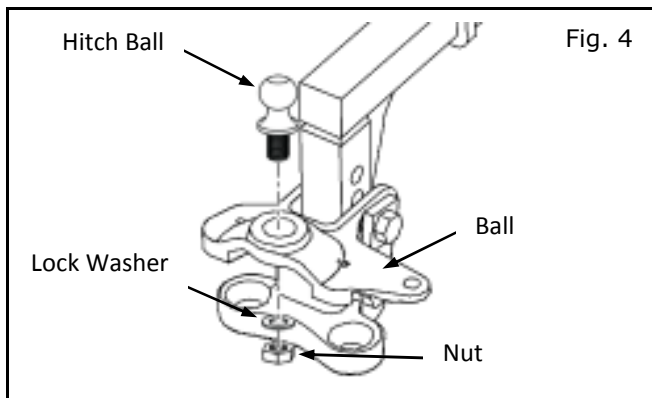

- 5) Installing Hitch Ball
 - a) Install hitch ball (T) into ball mount (A). Install lock washer (U) and nut (V). See Fig. 5. Torque nut to 450 ft./lbs.

NOTE:

Standard 2 5/16" height hitch ball with 1 1/4" shank is supplied with lock washer and nut. The bushing (B) provided allows for use of a 1" diameter shank hitch ball (not included in ...

INSTALLATION PROCEDURE:

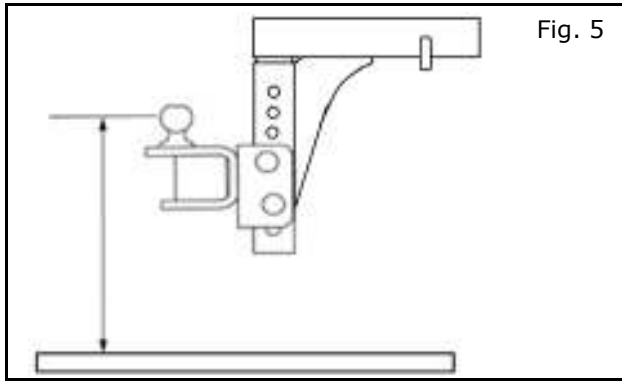

6) Adjusting Ball Mount

- a) Position ball mount on draw bar so hitch ball will be approximately 1/2" to 1" higher than coupler when in center of its tilt adjustment range. Reference coupler height measured in Step 2. Torque 3/4 nuts (F) to 300 ft. - lbs. See Fig. 5.

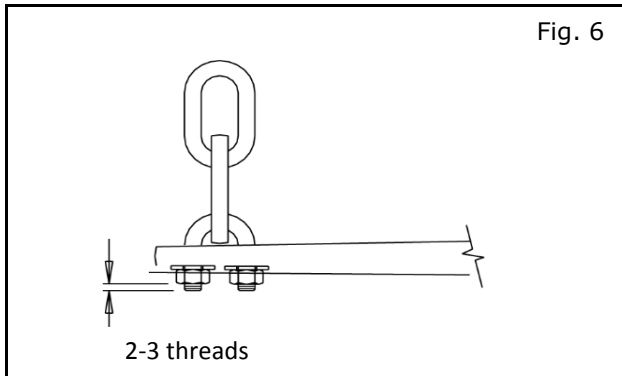

7) Installing Chains

- a) Attach chains (R) to spring bars (N) using U-bolts (S), flat washer (Q), and locknuts (P). Tighten until 2-3 threads protrude below locknut. See Fig. 6. Be sure that the chains do not bind.

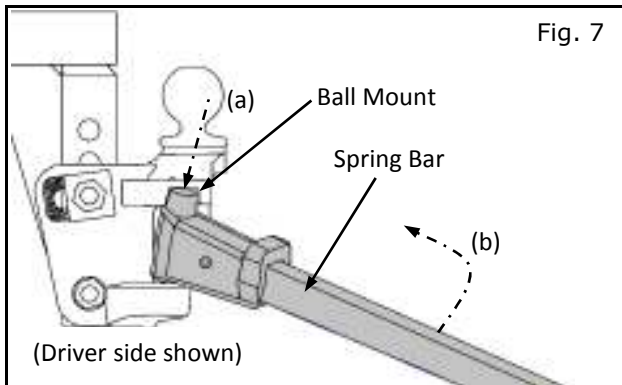

8) Installing Spring Bars

- a) Insert spring bar into ball mount at a slight angle so the upper portion clears the cut away provided.
- b) Rotate the spring bar forward into the trunnion until it comes to rest
- c) Repeat steps 8-a and 8-b for the passenger side.

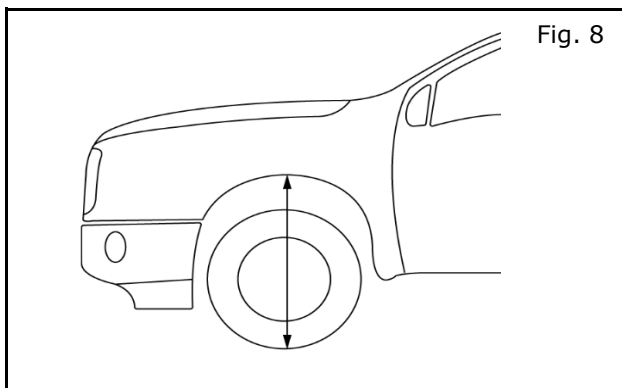

9) Leveling Vehicle

- a) Pick reference point on front wheel . Measure and record distance to pavement below. See Fig. 8.

Front Wheel Measurement: _____

NOTE:

Vehicle and trailer should be loaded and ready for travel before final leveling. Ensure all tires are properly inflated to the pressure indicated on the inside driver door.

INSTALLATION PROCEDURE:

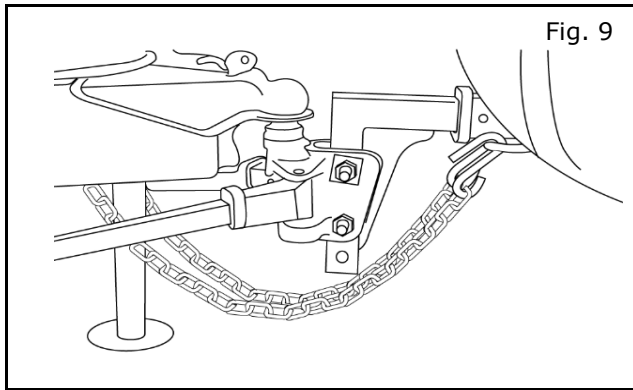

- 10) Leveling Trailer
 - a) Using tongue jack, lower coupler onto ball and close coupler latch.
 - b) Decrease the load on the rear of the vehicle by lowering trailer jack. Continue lowering trailer jack until front wheel well reference measurement is achieved.

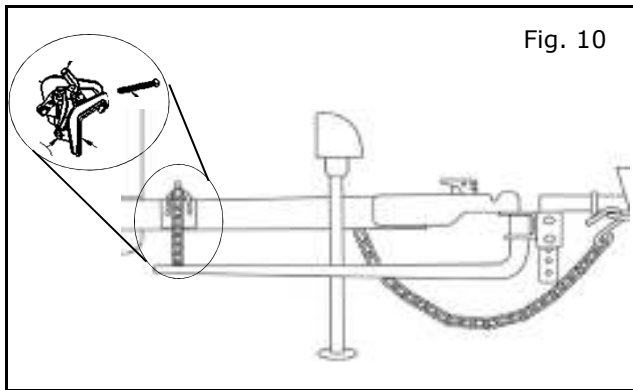

- 11) Installing Snap Up Brackets
 - a) Position snap up brackets (M) on trailer "A" frame so that chain on end of spring bar is approximately vertical. See Fig. 10
 - b) Install Snap Up Bracket attachment bolt. Torque bolt to 120 ft-lb. See Fig. 10

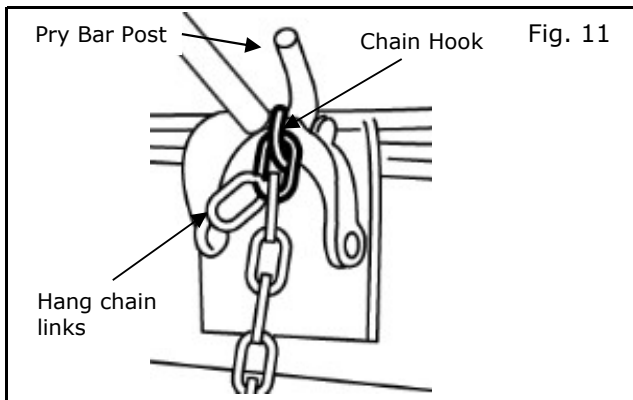

- 12) Installing Chain on Snap Up Bracket
 - a) Position snap up bracket so that lower jaw is point outward at 90° using the leverage handle (K).
 - b) Install chain onto chain hook feature. Pull chain upwards with moderate force and hang as many links as possible. Make sure to hang the same amount of links on each side. See Fig. 11
 - c) Using leverage handle (K), engage snap-up bracket. See Fig. 12.
 - d) Secure snap-up bracket with safety pin (L). See Fig. 13.
 - e) Repeat steps 12a through 12e for the opposite side.

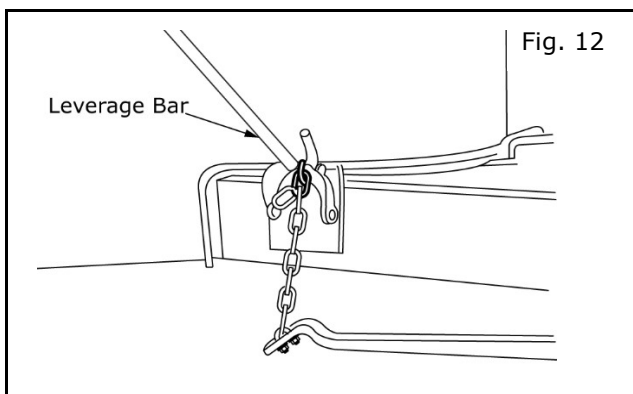

WARNING

- **If modification of your trailer's A-frame is required to install the snap up brackets, it is recommended you use a Nissan dealer or professional installation. Always consult the manufacturer of your trailer prior to making any modifications to your trailer.**

INSTALLATION PROCEDURE:

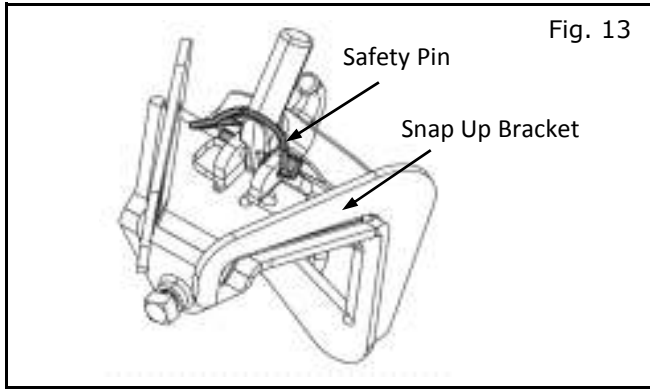

NOTE: Secure Safety Pin to Snap Up Bracket

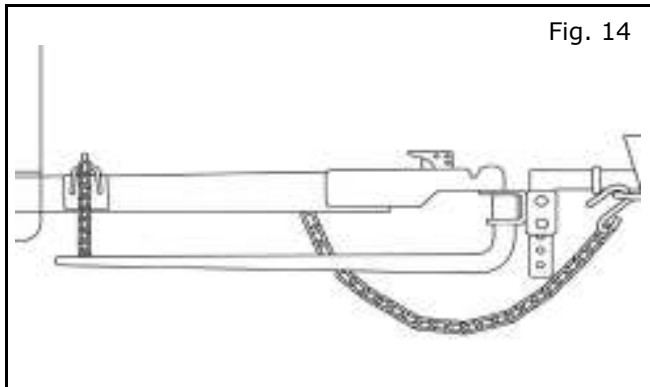

13) Completely raise trailer jack and stow properly.

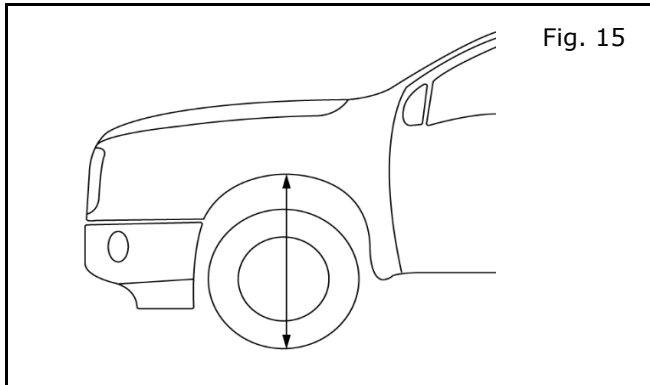

14) Confirm Front wheel well measurement.

NOTE:
It may necessary to re-adjust chain length to achieve the desired front wheel well measurement. If this is required, use trailer jack to remove the load from the vehicle. Then disengage Snap Up Bracket and adjust chain length. Then Repeat steps 12, 13 and 14.